

SIGNODE **HBX-4300**™

Semiautomatic plastic strapping machine

**Reliable
packaging
under harsh
conditions**

*for the
Meat, Poultry
and Seafood
industries*



Corrosion-resistant model shown.
Stainless steel model available.

Up to 70 straps per minute!

SIGNODE®

SIGNODE HBX-4300™

Semiautomatic plastic strapping machine

The new HBX-4300™ semiautomatic strapping machine is the simplest, most reliable general-duty strapping machine on the market today. With 40% fewer parts and more timesaving features, the HBX-4300 machine simplifies operation and maintenance to save you time and money.

Unmatched simplicity

The HBX-4300's simple yet durable design eliminates the use of drive belts and clutches. This combined with a number of other features make it easier to operate and maintain than other strapping machines.

- Jam-resistant technology
- Non-directional strap loading
- Out-of-strap feature
- Fully accessible strap path
- Toolless hot knife removal
- Automatic cut-off and refeed option

Reliable packaging

Designed for reliable packaging under harsh conditions, the HBX-4300 is available in either a stainless steel model or a corrosion-resistant model to suit your specific food processing packaging application. Both models offer a variety of features ideal for packaging applications where corrosion resistance is necessary.

Corrosion-resistant (CR) package

- Stainless steel roller table tops
- Stainless steel chute arch and covers
- Top mounted "yellow" power cable
- Lower splash guard panel
- Heavy duty 6" casters
- Heavy duty electrical door gasket
- Critical head and strap path components treated for corrosion resistance

Stainless steel (SS) package – All "CR" package components plus:

- Stainless steel frame
- Stainless steel rear panels
- Stainless steel dispenser door
- Stainless steel legs
- Stainless steel slack box
- Stainless steel electrical door

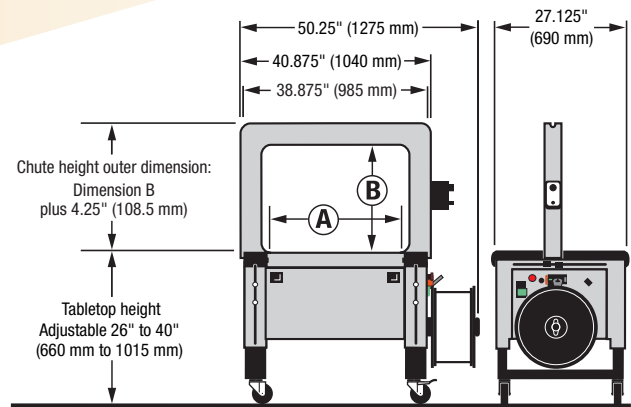

HBX-4300 Chute inner dimensions

	in.	mm
A*	28	710
B	20	510

*Inner dimension A is maximum package size.

HBX-4300 Specifications

Cycle rate: Up to 70 straps per minute. Actual production will vary depending on package size, chute size and operator dexterity.

Maximum package weight: 100 lbs

Strapping: 9 mm or 12 mm Contrax polypropylene strapping

Electrical requirements: 115 volt, 60Hz; 3 phase voltage optional

Shipping weight: 600 lbs

HBX-4300 Options

- Single or dual compression
Single: Up to 120 lbs at 90 lbs psi
Dual: Up to 240 lbs at 90 lbs psi
- Indicator light alerts operator to low strap/out-of-strap conditions and machine malfunction
- EZ height adjustable leg kit — 26" to 40" (660 mm to 1015 mm)
- Automatic cut-off and refeed

The HBX-4300 is also available in an automatic model, the HBX-4330.

SIGNODE®

3610 West Lake Avenue
Glenview, Illinois 60026
1-800-323-2464
www.signode.com

SIGNODE **HBX-4300**TM

Semiautomatic plastic strapping machine

- ***Unmatched simplicity***
Easy to operate and maintain
- ***Jam-resistant technology***
- ***Non-directional strap loading***

Up to
70
straps per
minute!



Made in
the U.S.A.

SIGNODE[®]

SIGNODE HBX-4300™

Semiautomatic plastic strapping machine

The new HBX-4300™ semiautomatic strapping machine is the simplest, most reliable general-duty strapping machine on the market today. With 40% fewer parts and more timesaving features, the HBX-4300 machine simplifies operation and maintenance to save you time and money.

Unmatched simplicity

The HBX-4300's simple yet durable design eliminates the use of drive belts and clutches. This combined with other trouble-free maintenance elements like toolless hot knife removal and jam-resistant technology make it easier to operate and more cost effective to maintain than other strapping machines.

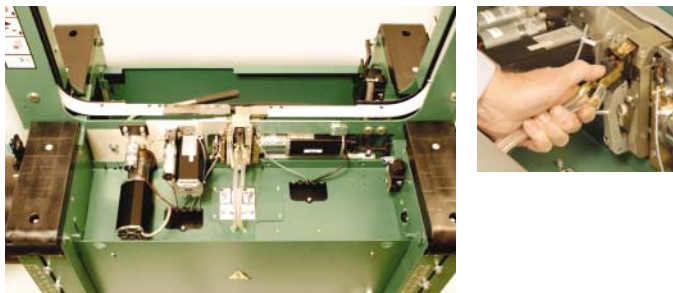

Strap feeds from either direction

Strap coil pays off from either direction, eliminating the downtime and material waste resulting from incorrect coil loading.

Out-of-strap feature

The out-of-strap feature ejects the strap at the end of the coil to eliminate downtime associated with removing the excess strap left in the machine.

Fully accessible strap path

No tools required. Simply raise the tabletop and lift guide for access to strap path.



Automatic cut-off and refeed option

Signode's patented automatic cut-off and refeed feature automatically ejects misfed strap, rethreads itself and continues strapping without operator intervention.

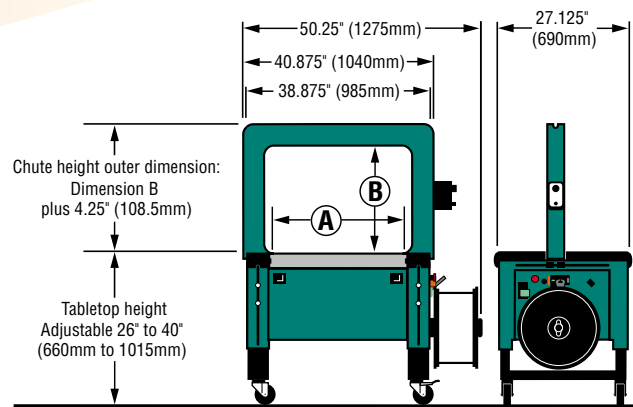

HBX-4300 Chute inner dimensions

	in.	mm	in.	mm	in.	mm	in.	mm	in.	mm
A*	16	405	20	510	28	710	33	840	48	1220
B	10	255	15	380	20	510	30	760	20	510

*Inner dimension A is maximum package size.

HBX-4300 Specifications

Cycle rate: Up to 70 straps per minute. Actual production will vary depending on package size, chute size and operator dexterity.

Maximum package weight: 100 lbs

Strapping: 9mm or 12mm Contrax polypropylene strapping

Electrical requirements: 115 volt, 60Hz; 3 phase voltage optional

Shipping weight: 600 lbs

HBX-4300 Options

- Single or dual compression
Single: Up to 120 lbs at 90 lbs psi
Dual: Up to 240 lbs at 90 lbs psi
- Indicator light alerts operator to low strap/out-of-strap conditions and machine malfunction
- EZ height adjustable leg kit — 26" to 40" (660mm to 1015mm)
- Automatic cut-off and refeed
- Roller top

The HBX-4300 is also available in a stainless steel model as well as an automatic model, the HBX-4330.

Save on strapping costs with HB Series plastic strapping

The new HBX-4300 utilizes Signode's newest Contrax® polypropylene strapping. HB Series strapping has the same durable properties as regular Contrax with more strap per coil.

- HB 612 9mm Contrax coils — 16,000 feet per coil
- HB 812 12mm Contrax coils — 12,000 feet per coil

SIGNODE®

3610 West Lake Avenue
Glenview, Illinois 60026
1-800-323-2464
www.signode.com